



HORECAROMA

**USE AND MAINTENANCE
MANUAL**

CE declaration of conformity

The manufacturer

Manufacturer - CAMAR s.r.l.s.

Registered office - Via Matteotti, 107

Postcode - 81030

Province - CE

City - Frignano

State - Italy

Email - camar@altapec.it

Website - www.macchinearoma.ch

Declares that the machine

Machine - ESPRESSO COFFEE MACHINE

Model - Bar 2.0

Year Built - 2021

CE declaration of conformity

Directive 2006/42/EC of the European Parliament and of the Council of 17 May 2006 relating to machinery and amending Directive 95/16/EC.
Directive 2014/35/EU of the European Parliament and of the Council of 26 February 2014 concerning the harmonization of the laws of the Member States relating to the making available on the market of electrical equipment intended for use within certain voltage limits.
Directive 2014/30/EU of the European Parliament and of the Council of 26 February 2014 on the harmonization of the laws of the Member States relating to electromagnetic compatibility.

Main references harmonized standards
EN12100:2010 Safety of machinery - General design principles - Risk assessment and risk reduction
EN 60335-1:2012 Household and similar electrical appliances
- Safety - Part 1: General requirements
EN 60335-2-41:2012 Household and similar electrical appliances
- Safety - Part 2-41: Particular requirements for pumps
CISPR 14-1:2016, CISPR 14- 2:2015, IEC 61000-3-2:2018, IEC 61000-3-3:2013, AMD1:2017

Summary

1. General information	5
1.1. Symbols to know	5
1.2. Manufacturer identification	6
1.3. Machine marking	6

2. Security	9
2.1 General warnings	9
2.2 Vibrations and noise emissions	10
2.3 Intended use	11
2.4 Residual risks	12

3. Description of the machine	14
--------------------------------------	-----------

4. Installation and use	16
4.1 Extraction of the coffee group	17
4.2 Adjustments	18
4.3 Steam group instructions	19
4.4 Standard packaging and transportation	20

5. Maintenance	21
5.1 Cleaning the pod holder	21
5.2 Descaling	22

6. Warranty	
6.1 The parties	24
6.2 Warranty information	24
6.3 Service procedures	25
6.4 Problems with transportation	27

7. Disposal	29
--------------------	-----------

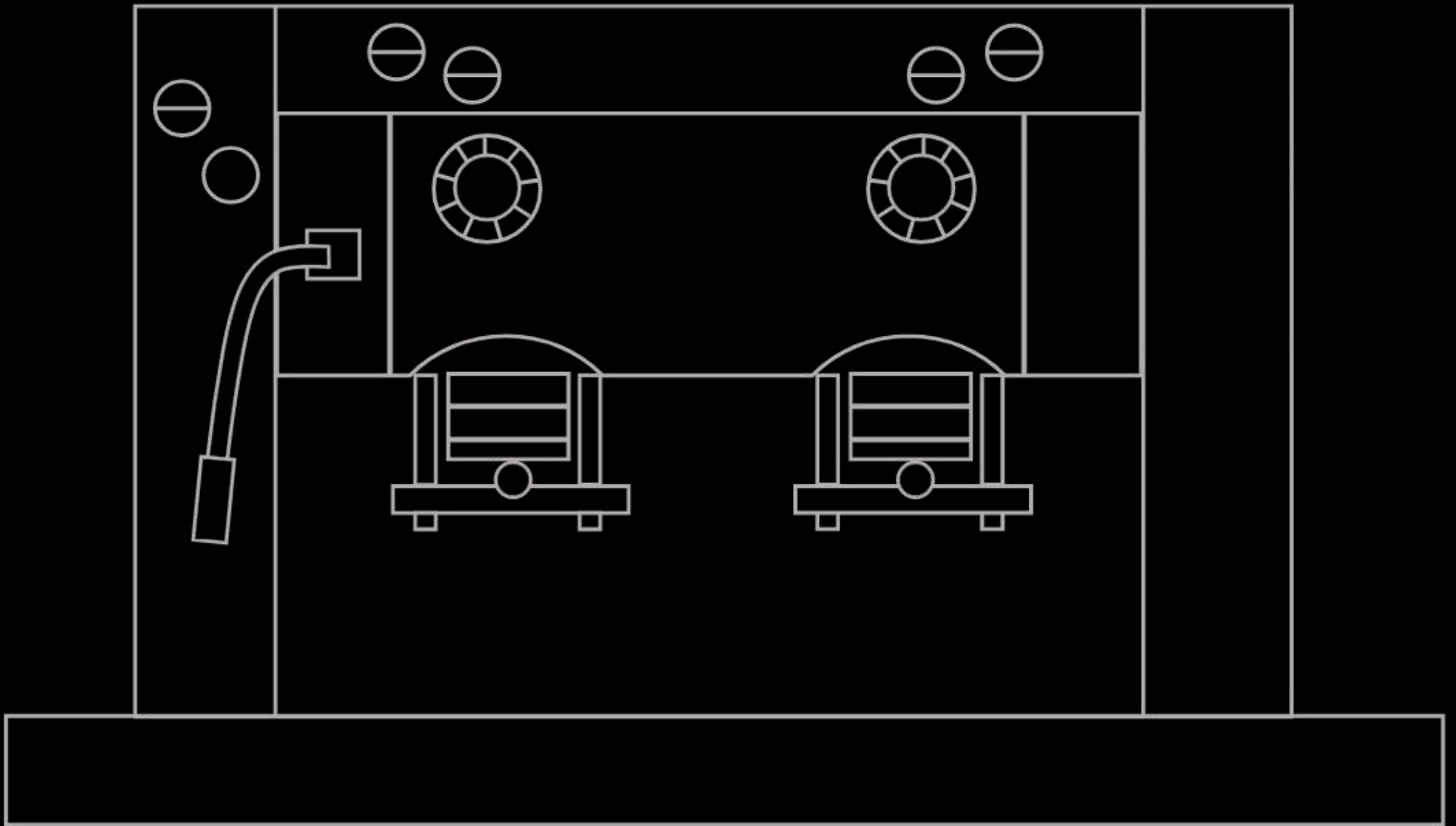

1 General informations

1. General information

1.1 Symbols to know

Attention

This symbol indicates the presence of danger for the user or damage to the product. Always follow the instructions when this symbol is present.



Danger of entrapment

This symbol indicates the presence of a risk of entrapment.



Information

This symbol indicates general information to simplify or better explain the use of the product.



Danger of burns

This symbol indicates hot surfaces, danger of burns.



Electrical hazard

This symbol indicates the presence of danger linked to the presence of electricity. Pay particular attention when this symbol is present. It is therefore necessary to respect the following safety warnings:

- Never touch the appliance with wet hands.
- Never touch the plug with wet hands.
- If the appliance is defective, do not attempt to repair it.
- Turn it off using the main switch (A19), remove the plug from the socket and contact Customer Service. - If the plug or power cord is damaged, they must only be replaced by customer service to avoid any risk.



contact info

This symbol indicates the contacts you can contact.



1. General information

1.2 Identification of the manufacturer

CAMAR s.r.l.s.

Manufacturer

Via Matteotti 107 81030

Frignano (CE)

Manufacturer
Registered Office

info@macchinearoma.com

www.macchinearoma.com

Contacts

1.3 Machine marking: the codes to know.

CE marking:

Each machine has a CE marking on the back, as required by European legislation, on which some of its technical data and manufacturer data are indelibly reported.

Fig.1



Fig.1

EAN:

The machine model, however, is identified by EAN code, a 13-digit code, present on the machine box. When the first digit is an 8, it indicates that the product is manufactured in Italy. Fig.2

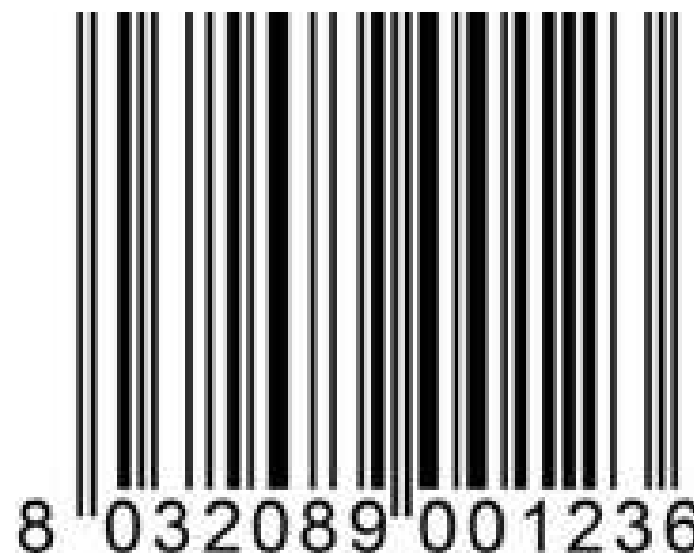

Fig.2

1. General information

Serial number:

For any communication to the Manufacturer or Authorized Assistance Centres, refer instead to the Serial Number, i.e. the 13-digit code, present both on the box and in the tank compartment, the first digit of which is a 2. This code precisely identifies the machine of which you are in possession of and contains a series of technical information useful to Assistance Centers and the Manufacturer. This Serial Number is essential, together with the proof of purchase, to be able to start a repair procedure under warranty. Take care to keep it. An example is shown in Fig. 3 and 4.



Fig. 3



Fig. 4

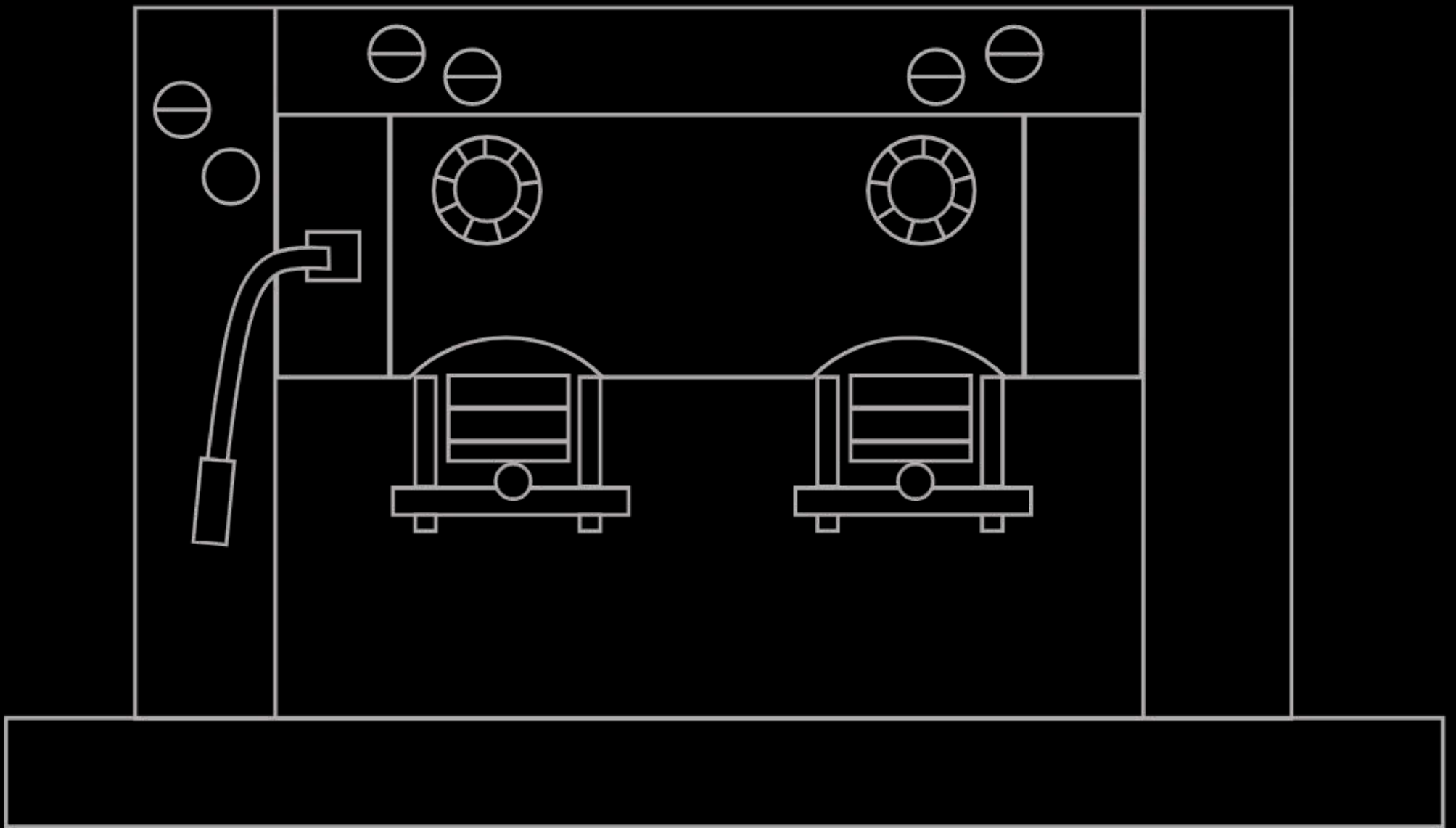

2 Safety

2. Security

2.1 General warnings

This manual has been created to provide the user with general knowledge of the machine and to allow its use in safe conditions. This Manual is an integral part of the machine and has the purpose of providing all the information necessary for: handling the machine in safe conditions; correct installation of the machine; knowledge of its technical specifications; correct use in safe conditions; technical assistance and spare parts management; the disposal of the machine in safe conditions and in compliance with the regulations in force to protect the health of workers and the environment. Furthermore, in compliance with the European standard IEC 60335-2-15, this Manual contains:



details on how to clean food contact surfaces

A warning of potential injury due to improper use, thorough knowledge of intended, unanticipated and unauthorized uses;



information that the heating element is subject to residual heat after use.

The instructions, documentation and drawings contained in this manual are of a confidential technical nature, strictly property of the Manufacturer. Therefore, outside of the purposes for which it was produced, any full or partial reproduction of the content and/or format must take place with the prior consent of the Producer. The Manual must be carefully preserved and must accompany the machine in all changes of ownership that it may have during its life cycle. No parts must be removed, torn or arbitrarily modified.

The Manual must be stored in an environment protected from humidity and heat and in the immediate vicinity of the machine to which it refers. The Manufacturer is held responsible only for the instructions drawn up and validated by the same. In any case, the Producer is not responsible for translations not approved by the same, in written form. The Manufacturer reserves the right to make changes to the project, variations or improvements to the machine and updates to the Manual without notice to customers.

2. Security

The updated version is always available and downloadable from our website
www.macchinearoma.com



Before operating the machine, carefully read the instructions contained in this Manual and carefully follow the instructions contained therein

The Manufacturer is relieved of any responsibility for damage caused by the machine to people, animals or property in the event of:

- improper use of the machine;
- defects in the electrical, hydraulic or pneumatic supply;
- incorrect installation;
- deficiencies in scheduled maintenance;
- unauthorized modifications or interventions;
- use of non-original or non-specific spare parts for the model;
- total or partial failure to comply with the instructions;
- use contrary to specific national regulations;
- disasters and exceptional events.

2.2 Vibrations and noise emissions

In conditions of use compliant with the instructions for correct use, the vibrations and noise emissions produced by the machine are not such as to give rise to dangerous situations. Before connecting your machine to the power socket, take the time to read these recommendations carefully, as they contain important information regarding safety and instructions for use.

- Read the instructions for use carefully;
- Never immerse the machine in water or other liquids (risk of electric shock);
- Start the machine by inserting the plug into an earthed socket (220-230 V) with differential protection and a minimum current of 6 A, 50Hz;
- Definitely unplug
 - before each movement of the machine;
 - before any cleaning or maintenance;
 - if the machine is not used for a prolonged period;
- Do not let the cable hang over corners or edges or get it stuck (danger of electric shock);

2. Security

- To avoid risks, have damaged cables replaced;
- Never touch the plug/cord and the machine with damp or wet hands;
- Always pull the plug and never the cable;
- If an extension cable is needed, make sure it is suitable for the machine (3 poles with earth and a wire section of at least 1.5 mm²);
- Check that the cable does not cause you to trip;
- Never move the machine during use (risk of burns and electric shock);
- During operation, various parts of the machine body, such as the dispensing unit and the pod press, become hot: do not touch.

2.3 Intended use

The BAR 2.0 espresso coffee machine is intended for the preparation of drinks using espresso coffee pods.

In compliance with IEC 60335-2-15, the machine can be used for the following uses:

- kitchen areas for staff in shops, offices and other work environments;
- farmhouses;
- by customers in hotels, motels and other residential environments;
- bed and breakfast environments and similar.

The machine must not be used:

- for uses other than those established by the Manufacturer, different or not mentioned in this Manual;
 - exposed to bad weather;
 - with electric jumpers and/or mechanical means that exclude users/parts of the machine itself;
 - in an environment with hygienic characteristics unsuitable for food production.
- Keep the appliance and its cable out of reach of children under the age of 8;

Children must not play with the appliance; The appliance is not intended to be used by people (including children) with reduced physical or mental capabilities.

The manufacturer cannot be held responsible for any commercial and/or image damage, nor for damage to things or people caused by improper use of the appliance. Any dispute will be referred to the court of Santa Maria Capua Vetere. The data and characteristics indicated do not bind the manufacturer, which reserves the right to make changes to the appliances at any time.

2. Security

2.4 Residual risks

When using the machine it is necessary to pay attention to the residual risks:

- Do not wet live parts, risk of short circuit;
- Overheated steam and hot water can cause scalding.

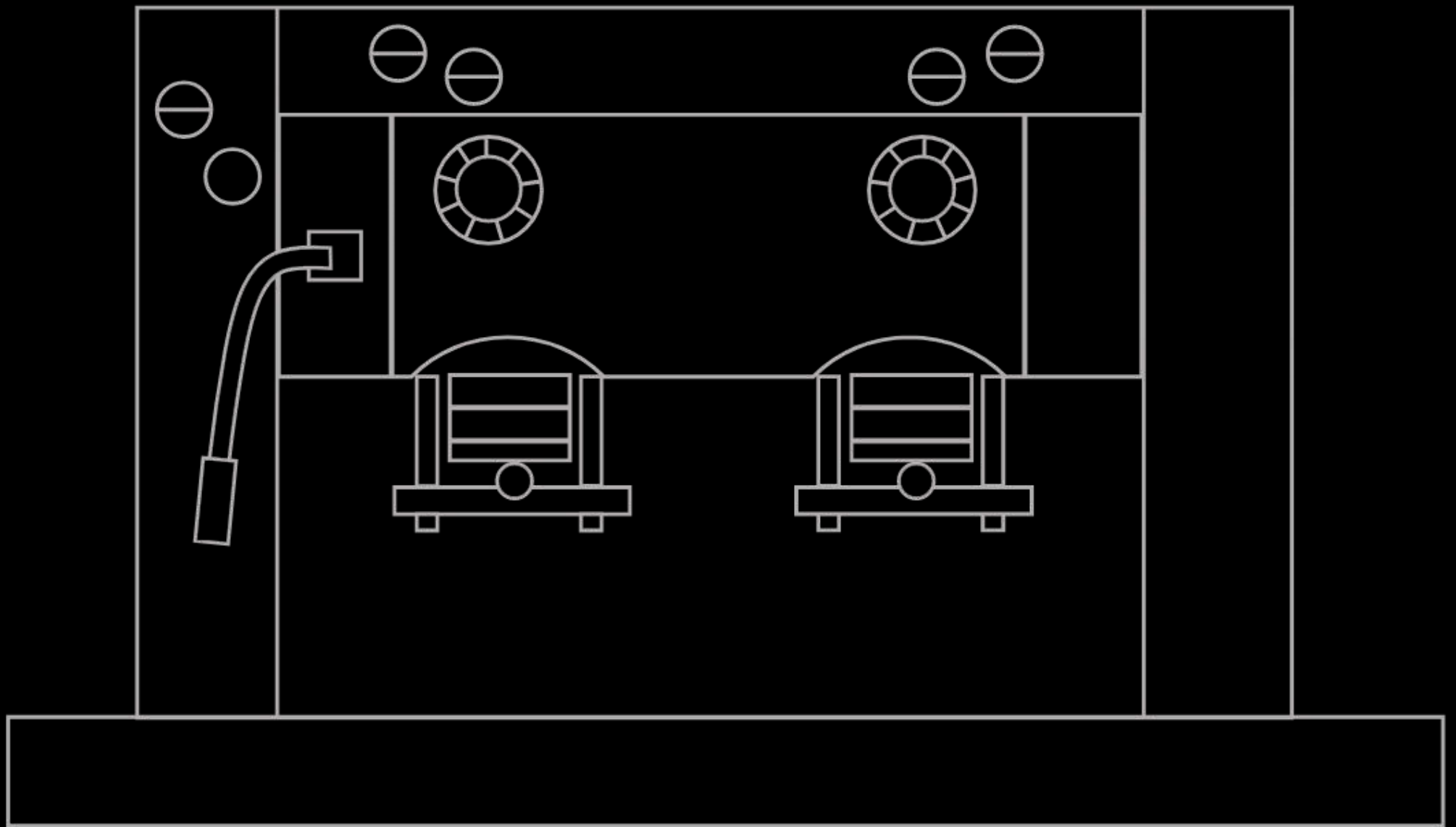

3 Description of the machine

3. Description of the machine

3. Description of the machine

1. Coffee on button
2. Coffee dispensing button
3. Steam wand
4. Steam wand power button
5. Steam wand delivery button
6. Coffee group closing knobs
7. Coffee dispenser filter holder
8. Drain tray

SUPPLY VOLTAGE: AC 220-230

PUMP: 15 BAR

MAXIMUM POWER: 1600W

430MM LENGTH

510MM DEPTH

510MM DEPTH

400MM HEIGHT

CABLE LENGTH: 1400 MM

WEIGHT: 30 KG

SHELL MATERIAL: METAL

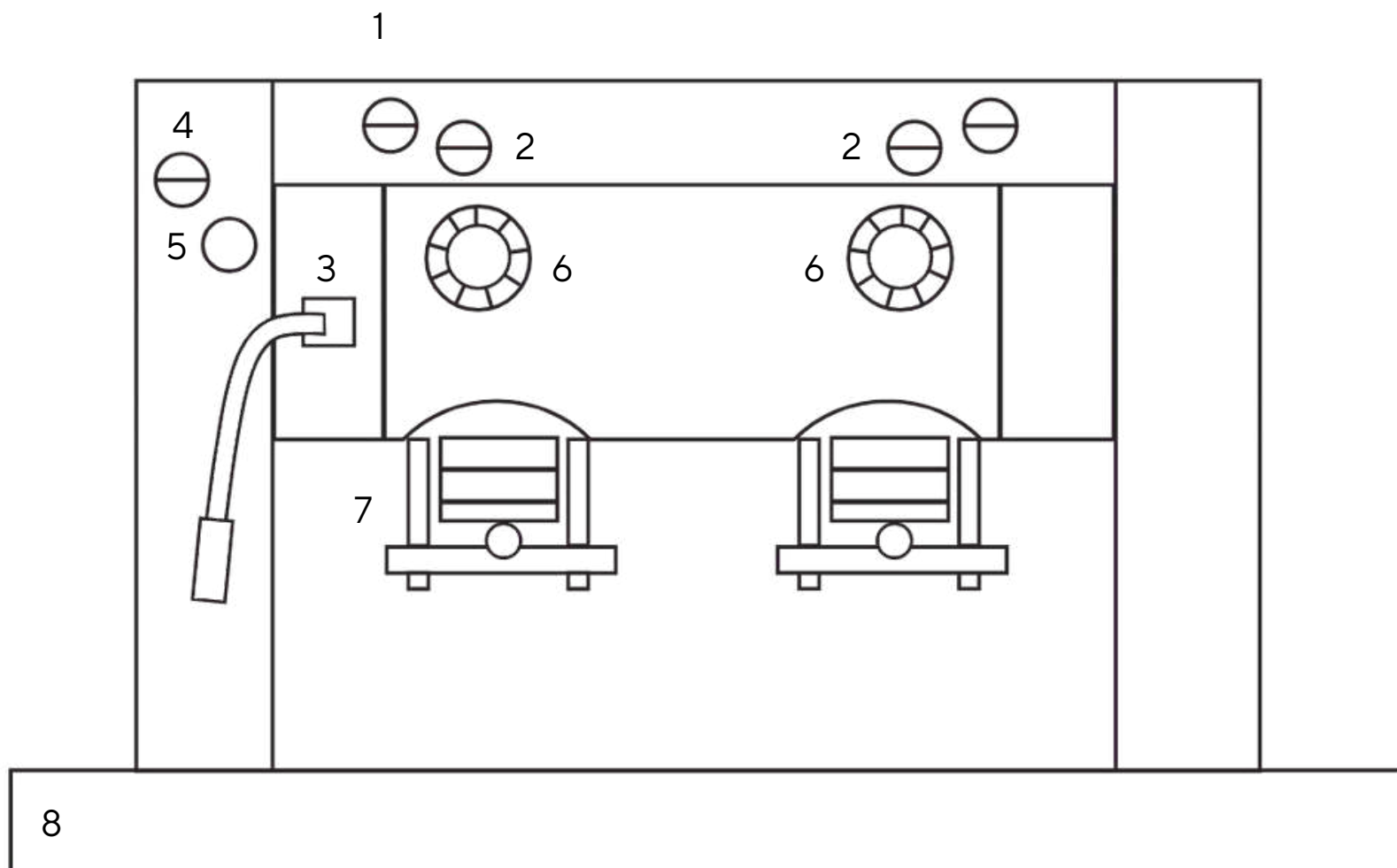

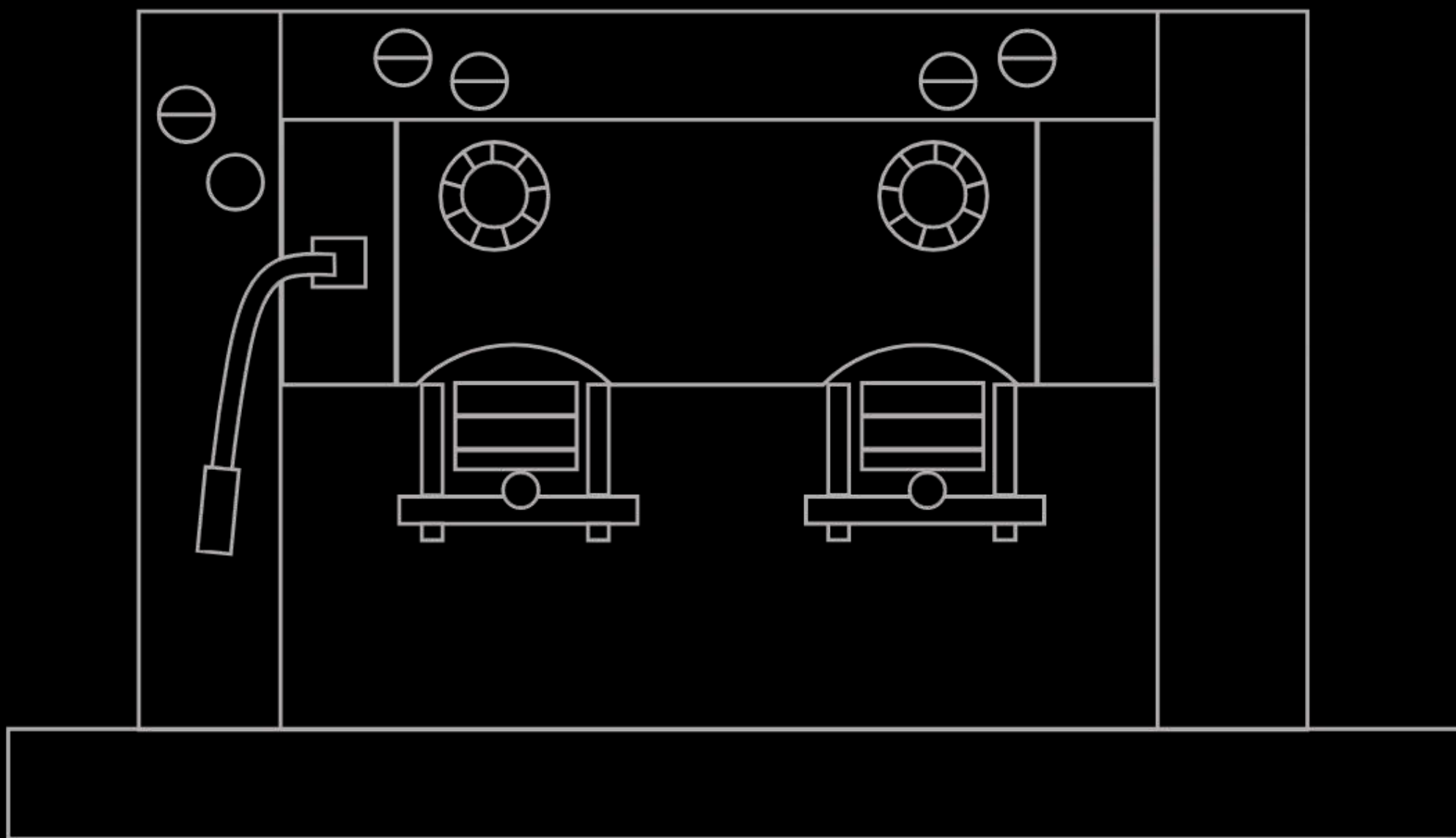

4 Installation and use

4. Installation and use

4. Installation and use

The installation of the machine must be carried out in such a way as to optimize the ergonomics and safety of the workplace: leave sufficient area around the machine to allow easy use, maintenance and adjustment operations. The machine must be installed in a system socket compliant with the country of installation, with relative earthing. HorecAroma machines intended for the Italian market require a 220-230 V, 50 Hz system. Check the technical characteristics on the CE marking, located on the back of the machine.



ATTENTION!

The manufacturer is not responsible for damage to people, animals and property caused by non-compliance with this provision.

The machine is suitable for operating in environments with temperatures between + 5°C and + 40°C.



Only coffee pods must be inserted into the pod holder. Do not insert your fingers or any other object.

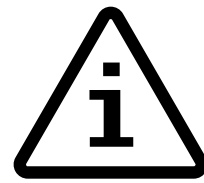

The single-dose pods are designed to brew a single coffee. Do not reuse the pods after use.

- 1) Remove the machine from the box and make sure it is intact.
- 2) Test the machine on a homogeneous surface, so as to adhere well to the surface with all four feet.
- 3) In case of water connection, follow the steps in point 4.1, before turning on the machine.
- 4) In the absence of a water connection, however, remove the water tank and fill it (Fig. 1). The tank can be removed by lifting the cap located on the top of the machine. After filling the tank, reinsert it into the machine and close it with the black plastic cap, for hygiene reasons. Make sure you have also inserted the suction tube into the appropriate hole before closing the machine with the stainless steel cap.



Fig. 1

4. Installation and use

4.1 Coffee group instructions

The coffee groups have independent ignition. Each coffee group can be turned on independently using the power button located at the top. (Fig. 2). Each group also has a dispensing button next to the power button. The power button has a green light, which indicates that the group has been turned on, while the dispensing button has a red light which indicates that the group is heating up.

- 1) Make sure the water tank is full before turning on the coffee groups.
- 2) Press the power switch of the group you want to turn on. A red light will come on on the dispensing button (with the cup). When the temperature light is off the machine is ready for brewing.
- 3) Lift the lever.
- 4) Keeping the lever raised, place the pod on top of the pod holder. Make sure it is inserted correctly (Fig. 3).
- 5) Lower the lever until you hear a click.



Fig. 2



Fig. 3



Fig. 4

4. Installation and use

6) Press the coffee dispensing switch (the one with the cup symbol) and the machine starts dispensing coffee (Fig. 4).



ATTENTION!

During dispensing, do not lift the closing lever.

7) Press the switch again to stop dispensing.

8) It is advisable to remove the used pod immediately after dispensing, to avoid unpleasant odors due to a used pod left inserted for a long time and/or losing the seal. To do this, lift the closing lever and remove the used pod.

Adjustment of the coffee group

The hardness of the lever and therefore the consequent pressure on the pod can be adjusted in different ways based on the model purchased. Generally speaking, greater pressure (harder lever at closing) allows the edge of the pod to get less wet or not get wet at all and the coffee to be dispensed in a creamier way. The lower the pressure (the softer the lever), the more the pod will tend to wet the edges and the faster and less restricted the coffee will be delivered.

The adjustment in these models occurs by rotating the brass pod press (Fig. 5).

By turning the pod press to the right the closure will tend to soften. By turning it to the left the closure will tend to harden.

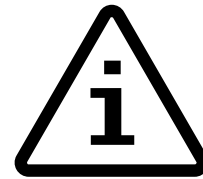

ATTENTION!

Do not touch the pod press while the machine is on, it is a hot part, so there is a risk of scalding. Therefore adjust with the machine off, or with the help of a stick-like object, inserting it into the guide holes on the pod press.



Fig. 5

4. Installation and use



Do not touch the pod press while the machine is on, it is a hot part, so there is a risk of scalding. Therefore adjust with the machine off, or with the help of a stick-like object, inserting it into the guide holes on the pod press.

4.3 Steam group instructions

The steam unit has independent ignition. The unit can be turned on independently using the power button located at the top. The group also has a dispensing button next to the power button.

The power button has a green light, which indicates that the group has been turned on, while the dispensing button has a red light which indicates that the group is heating up.

1) Make sure the water tank is full before turning on the steam unit.

2) Press the power switch of the group you want to turn on. A red light will come on on the dispensing button. When the temperature light is off the machine is ready for steam.

4.4 Standard packaging and transportation

The standard packaging includes:
Carton box;
Protection envelope.

During independent transport, take care that the machine does not come into contact with water or is subject to impacts and that it is transported in the correct direction (see "HIGH" written on the box).

In case of inactivity, the machine must be stored taking the following precautions:

Turn off the machine and disconnect the power supply;

Empty the tank and the drain tray of the machine;

Store the machine in a closed place;

Protect the machine from impacts and stress;

Protect the machine from humidity;

4. Installation and use

Prevent the machine from being subjected to extreme temperatures and protect it from high temperature variations;

Prevent the machine from coming into contact with corrosive substances;

Avoid inactivity for more than 6 months. In similar cases it is advisable to turn on the machine and make a few deliveries, and then store it again.

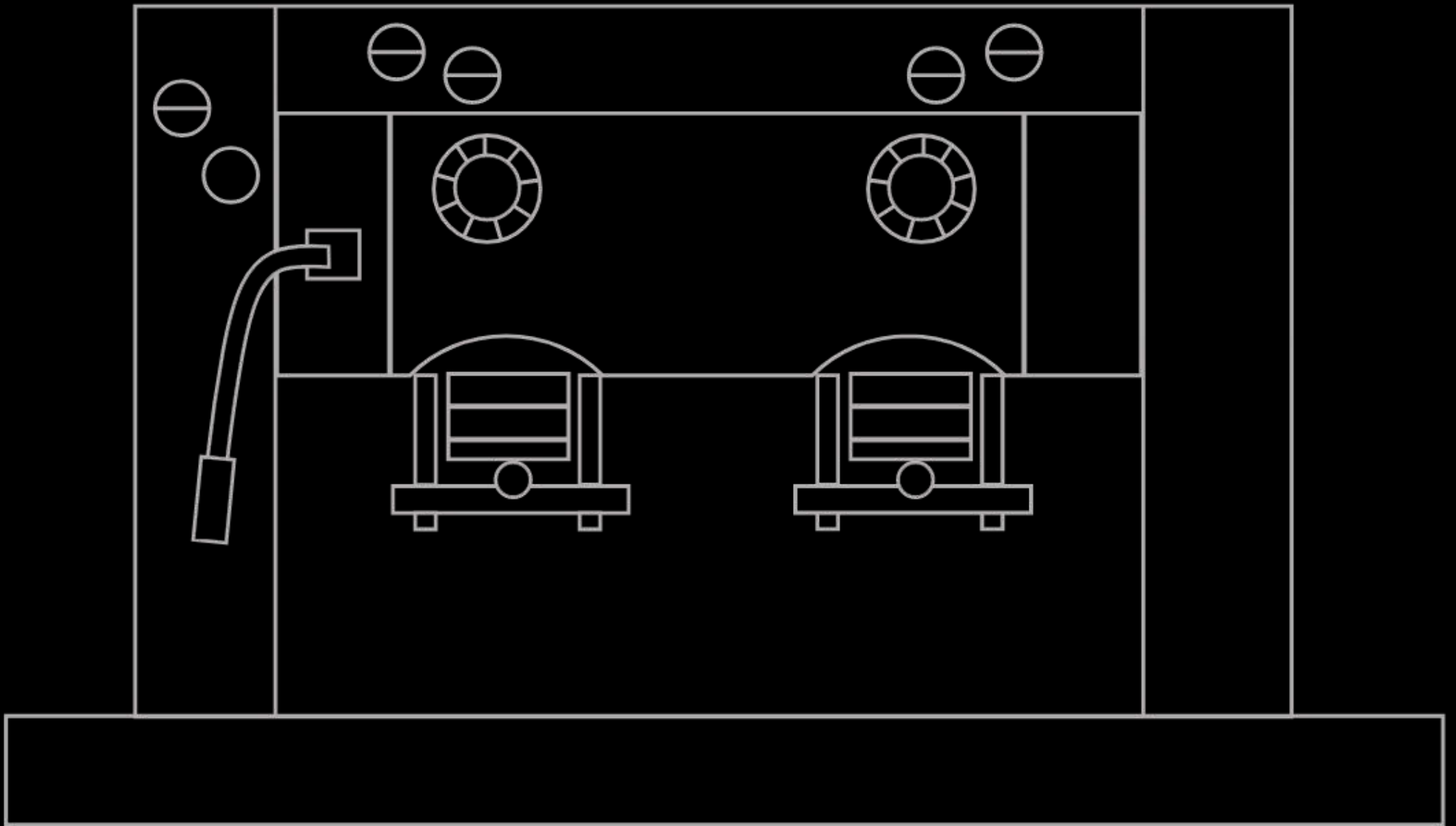

5 Maintenance

5. Maintenance

5. Maintenance

Before carrying out any type of cleaning, it is necessary to isolate the machine from the electrical supply and wait for it to cool down.



Never use alkaline detergents, solvents, alcohol or aggressive substances or ovens to dry machine components.

Wash the components (excluding the electrical ones) with cold/lukewarm water and non-abrasive cloths/sponges and with the Aroma cleaning products you can find on our website or at our authorized retailers.

5.1 Cleaning the pod holder

Carry out the pod holder cleaning procedure weekly. To disassemble the pod holder (Fig. 1, 2 and 3):

- Rotate the spout to the right;
- Lift the pod holder;
- Hold the steel filter with the other hand;
- Unscrew the filter, turning it to the right or left;
- Rinse under running water.

To assemble the pod holder:
- Screw the filter onto the pod holder;
- Place the filter holder in the appropriate housing; - Rotate to the left.



Fig. 1



Fig. 2



Fig. 3

4. Installation and use

5.2 Descaling

The formation of limescale is a normal consequence of using the appliance; descaling is necessary every 3-4 months of use of the machine and/or when a reduction in water flow is observed. The frequency of descaling also changes based on the hardness of the water used. Always use packaged water or water with low limescale content. For descaling use only Aroma CLEANER.

Why use Aroma CLEANER:

- a) It is the only certificate for contact with food;
- b) It is based on melic and citric acid, therefore based on natural acids;
- c) It is delicate with surfaces and does not corrode them; keeping the mechanical parts intact;
- d) It is tested on HorecAroma products;
- e) It is biodegradable, respects the environment;
- f) It is ready to use, for simple use.



Failure to comply with what is requested exempts the Manufacturer from any liability for the purposes of the Guarantee.

Method of use

- Pour the entire contents of the 250 ml bottle into the appropriate water tank without diluting;
- Turn on the machine and dispense the product 15 ml at a time intermittently;
- Leave to act for 5-10 minutes and repeat the operation until the descaling solution is complete;
- Rinse the tank with drinking water: fill it and then rinse the appliance by dispensing approximately 1000 ml of drinking water;
- Make sure that everything has remained unchanged and proceed with dispensing the coffee.



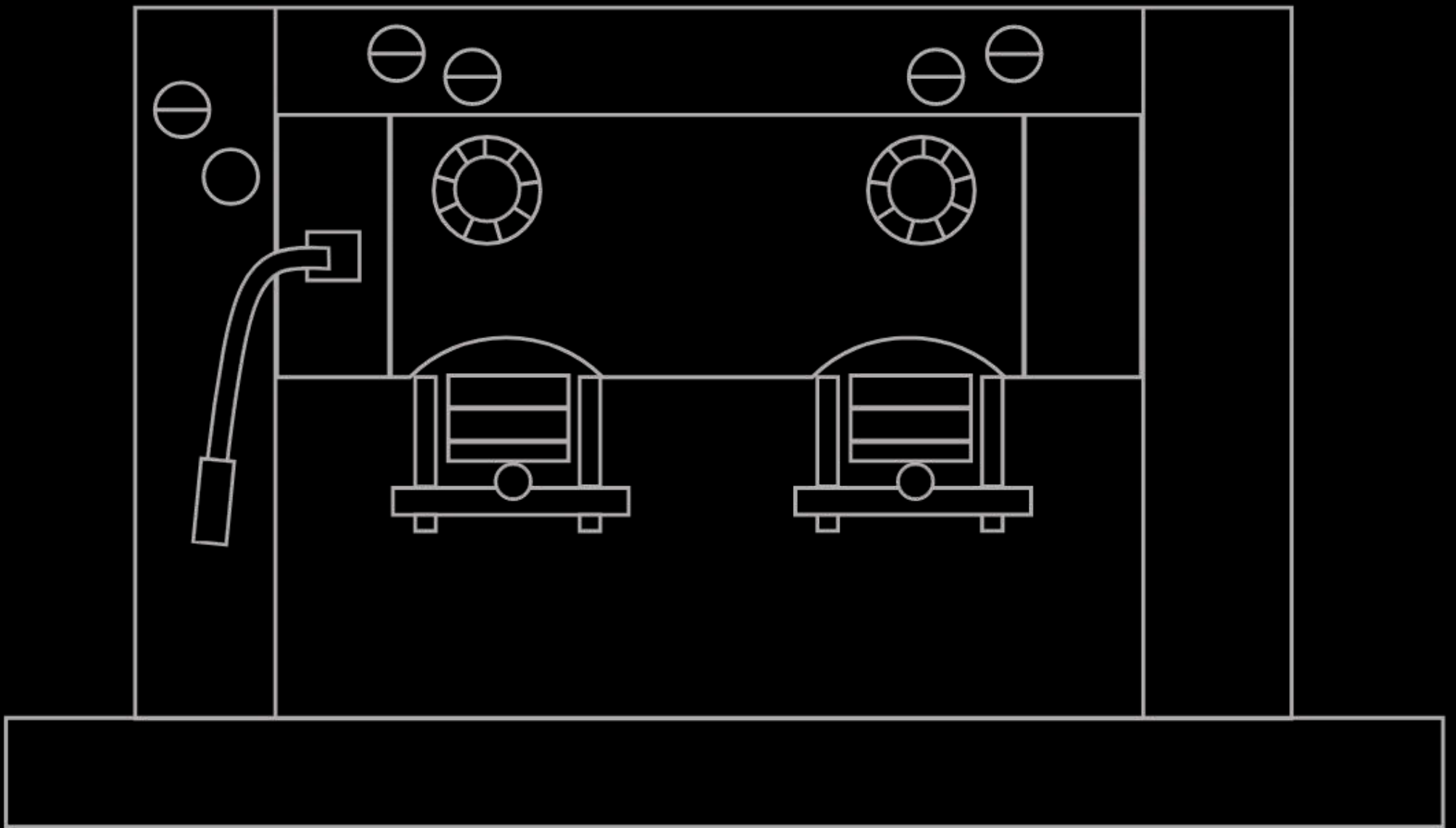

6 Warranty

6. Warranty

6.1 The parties

THE MANUFACTURER: CAMAR s.r.l.s. owner of the brand and manufacturer of the machine.

THE SELLER: The company that buys the producer's good and resells it to the final consumer.

THE CONSUMER: Natural person who purchases the good for his own use. The consumer is the actual user of the good.

6.2 Warranty information

If during the validity period there are malfunctions or failures of parts of the machine attributable to defects in construction, materials or workmanship, the Consumer or the Seller is required to promptly inform the Manufacturer in writing by filling out the form on the website www.macchinearoma.com/assistenza/ or via the email address amministrazione@macchinearoma.com. The Manufacturer, after appropriate checks of the information received, authorizes the Seller who will repair or replace the defective parts. The guarantee begins

from the date shown on the proof of purchase, showing the machine serial number, stamp and signature of the Seller. Possession of this document, together with the Serial Number on the machine itself, are a necessary condition for activating a repair or replacement under warranty. Replacement is possible if the report reaches the Manufacturer within 7 days of purchase. Otherwise, the machine can be repaired.

Cases not covered by warranty:

Damage not attributable to defects in workmanship, construction or materials;

Damage caused by careless transport and/or handling;

Damage caused by improper use of the machine or not foreseen in this Manual;

Failure to carry out routine maintenance as required by this Manual;

Faults and/or breakages attributable to accumulations of limescale or coffee;

6. Warranty

Faults caused by electrical surges and short circuits;

Faults and breakages not attributable to machine malfunction;

For all other causes not attributable to the Manufacturer;

Damage caused by modifications and/or interventions not authorized by the Manufacturer;

Failures of parts subject to wear (o-rings, buttons, filter holder, etc...);

Scratches or aesthetic defects caused by transport;

Pump malfunction due to lack of water in the tank.

The machine also loses the right to the guarantee if it is opened and/or tampered with without explicit written authorization from the supplier. Furthermore, unauthorized modification or improper use relieves the Manufacturer of any liability for damage caused by a defective product.

The use of non-original spare parts compromises the proper functioning of the machine.

Request and use only original HorecAroma maintenance products and spare parts.

6.3 Assistance procedure

The legal guarantee is the responsibility of the Seller, and lasts 24 months. If you have problems with yours, contact your trusted dealer.

If your Seller is not available, let us know and take advantage of the Aroma guarantee by filling out the form on our website

www.macchinearoma.com/sistenza/ as follows:

- a) Attach proof of purchase;
- b) Attach photo of the freshman;
- c) Specify the problem encountered, attaching photos and videos that clearly show it;
- d) Specify any inefficiencies of the retailer.

6. Warranty

6.4 Problems with transportation - procedure

Any defects evidently and visibly present at the time of delivery of the product (aesthetic defects on visible parts, breakages, dents, operational defects, missing parts, etc.) must be reported to the seller within 7 days of purchase in order to benefit from the replacement.

As soon as you receive the package, check that it is intact before signing the delivery receipt.

In the event of visible damage, non-compliant or damaged packaging upon delivery by the courier or other appointed carrier, follow the following procedure:

- 1) Sign the document to the courier with the "Reservation of control" clause;
- 2) Produce photos and/or videos clearly highlighting the nature of the damage caused;
- 3) Send an email to assistance@macchinearoma.com, or to the Seller's email within 24 hours of delivery, with the following info:

- a) If possible, the document signed with "Control reservation";
- b) Photos and/or videos produced;
- c) Precise number of damaged packages or boxes.

Once the email has been received, our Customer Care will proceed to open the complaint with the carrier. In the meantime, the quickest and smartest resolution of the problem will be evaluated, through integration of the damaged parts, repair or replacement of the goods.

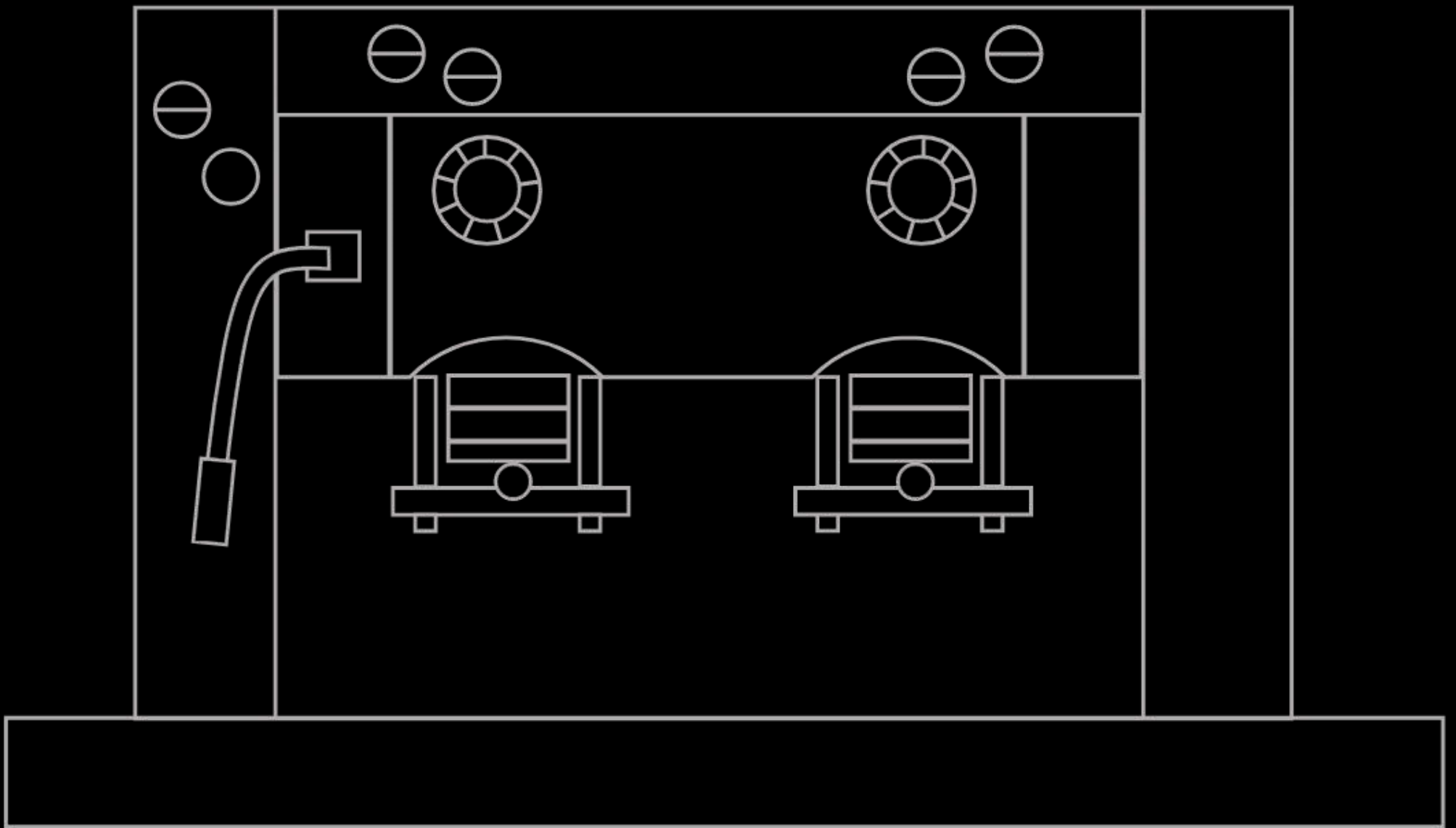

7 Disposal

7. Disposal

7. Disposal

Pursuant to art.26 of Legislative Decree 14 March 2014, n.49 "Implementation of Directive 2012/19/EU on waste electrical and electronic equipment (WEEE), relating to the reduction of the use of dangerous substances in electrical and electronic equipment electronic devices, as well as waste disposal", the crossed-out wheellie bin symbol shown on the equipment or its packaging indicates that the product must be collected separately from other waste at the end of its useful life.



In compliance with the WEEE Directive 2012/19EU:

The user must, therefore, deliver the equipment which has reached the end of its life to suitable separate collection centers for electronic and electrotechnical waste, or,

return it to the retailer when purchasing a new appliance of an equivalent type, on a one-to-one basis.

Adequate separate collection for the subsequent sending of the decommissioned equipment for recycling, treatment and environmentally compatible disposal contributes to avoiding possible negative effects on the environment and health and promotes the reuse and/or recycling of the materials it is made of the equipment. Illegal disposal of the product by the user entails the application of administrative sanctions provided for by current legislation.

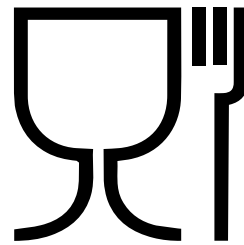

AROMA products are compatible with EC regulation 1935/2004.

CAMAR s.r.l.s.

Via Matteotti 107 – 81030 Frignano (CE)

www.macchinearoma.com